

# DEHA

GROUP



---

[www.dehametal.com](http://www.dehametal.com)

IRON & STEEL **DEHA**

IRON & STEEL

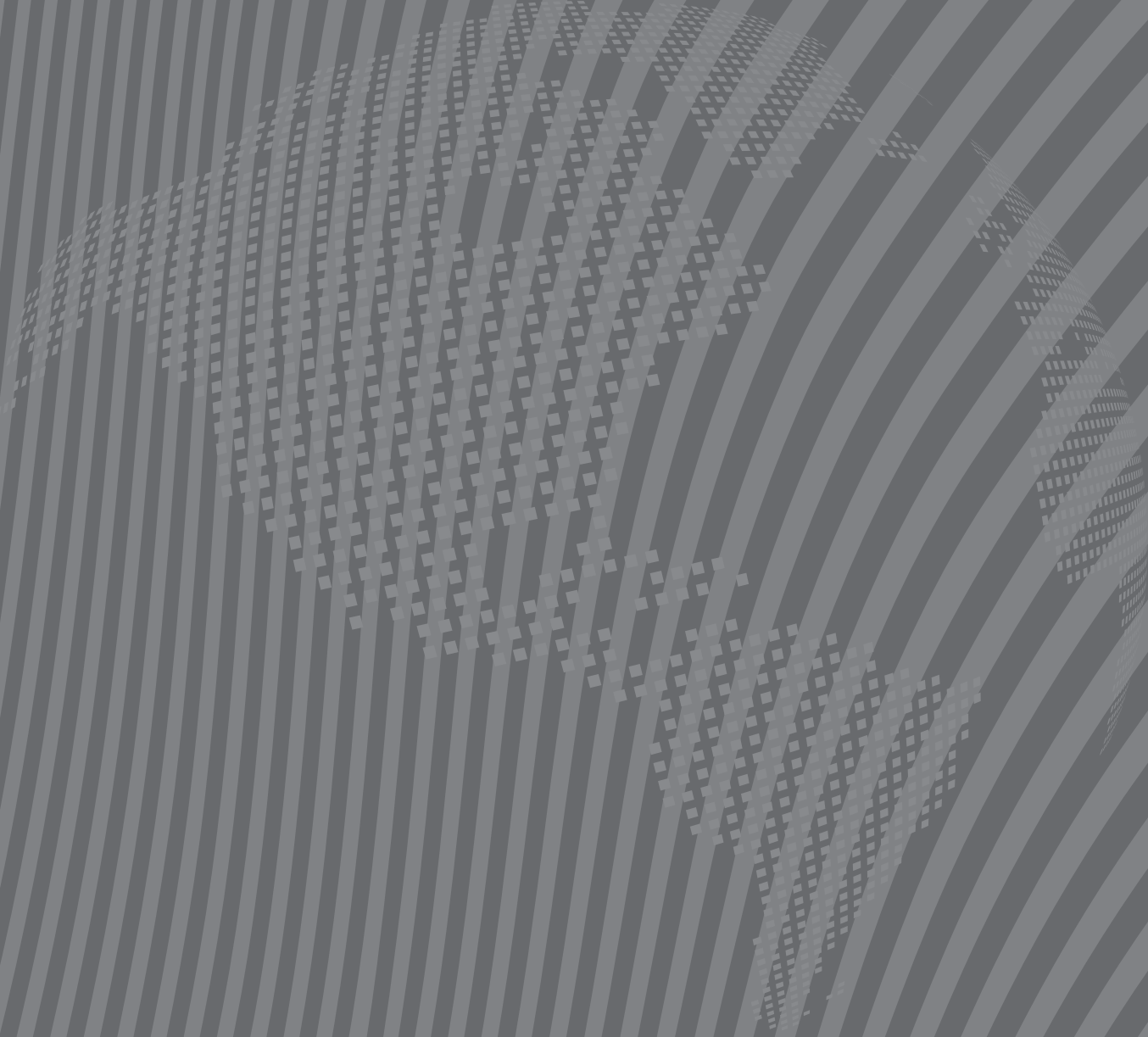

   [in /dehagroup](https://www.linkedin.com/company/dehagroup)

07-09

**SERVICES**

---

10-13

**PROFILES**

---

14-15

**PIPES**

---

16-19

**SHEETS**

---

20

**REBARS**

---

21

**ENGINEERING STEELS**



**We serve with the aim of meeting all iron and steel needs of users in a wide range with quality production, economic solutions, fast and flexible service.**



## Deha Steel & Iron Company

DEHA Group was established as a supply and manufacturing center in İstanbul region in order to serve the Iron / Steel sector of our country and offers a wide range of products to our valuable industrialists and manufacturers with more than 20 years of work experience and sector experience.

Our 4.000 m2 production facility is located in Tuzla Deri Sanayi and our machine park includes Sheet Metal Laser Machine, Pipe-Profile Laser Machine, Press Brake Bending Machine, Angle Guillotine, Shear Machine and Fully Automatic Band Saw Machine.

Our product range includes Pipe – Profile, Sheet Metal (Black, Dkp, Hrp, Baklava, Galvanized, Stainless Aluminum and Hardox), Npi, Npu, Hea, Heb, Ipe, Equilateral Angle Bar, Flat Bars, Square, Rebar, Steel Mesh, Cold Drawn or Hot Rolled Steel Bars, Automaton Steels, Transmission Shafts, Carbon Steels (ck45, s355 etc.) Reclamation Steels and Tool Steels.

We also have a retail stock warehouse at the same location. With our own vehicles, we are happy to provide you with material supply services in cut or full length, regardless of the minimum quantity. In addition, Steel Construction manufacturing and Welded manufacturing as well as Project Design processes are implemented and followed.

Our company, whose main goal is to offer products that create added value, always prioritizes investment in people with its expert technical team and experienced management team and prioritizes sustainable development.



DEHA HADDECİLİK

5 TON

YÜKLEME  
ALANI





## Bending Machine

With our 8 Axis Full Cnc Press Brake Machine with 240 Ton Power, sheet metal bending process is performed up to 10 mm thickness and 4100 mm length.



## Pipe-Profile Laser Machine

Our Pipe-Profile laser line has a power of 6 KW and can laser cut Pipe, Profile and Long rolling products up to 6500 mm length, minimum 8 mm maximum 350 mm diameter up to 12.00 mm thickness.





### Laser Machine

We have 2 machines, 22 KW and 6 KW, in sheet metal laser processes. Our 22 KW machine is 2500\*6500 in size and can cut up to 60.00 mm thickness. Our 6 KW machine is 1500\*3000 in size and can cut up to 22.00 mm thickness.



### Angle Strip Saw Machine

Our fully automatic electronic straight and angle band saw has a cutting capacity of 400 x 400 mm and a motor power of 4 kW. It offers high precision, easy operation, fast and efficient cutting and safe operation with variable cutting speed between 20-120 m/min, electronic speed control, -45°/+60° miter angle, hydraulic clamp, cooling system, fast approach and return functions and digital display.







### Hydraulic Guillotine Angle Shear

With a table length of 3100 mm and a cutting thickness of up to 13 mm, this angle shear hydraulic guillotine machine is the ideal solution for cutting sheet metal with precision and speed. With its hydraulic power system, it offers high capacity and easy operation, while its adjustable cutting angle and precise cutting process allows us to achieve excellent results in metal cutting operations.



### Welded Manufacturing

We can make welded or twisted manufacturing with our professional expert staff. The main applications of our expert staff are Roof Space Systems, Roof Manufacturing, Steel Construction, Iron Stairs, Iron Railing, Machinery Equipment and Machinery spare parts etc. We manufacture the products in our facility or in the assembly area.



**NPU  
PROFILES**

**TS** 912  
**DIN** 1026

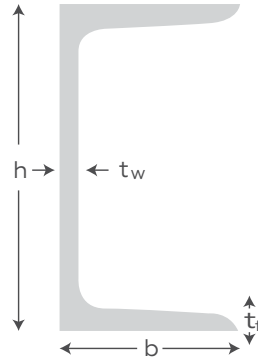

Dimensions (mm)			
h	b	tw	tf
30 - 400	15 - 110	4 - 14	4,5 - 18

**IPE  
PROFILES**

**TS** 910/1  
**DIN** 1025

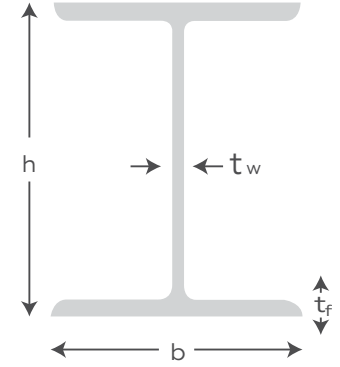

Dimensions (mm)			
h	b	tw	tf
100 - 753	55 - 265	4,1 - 13,2	5,7 - 17

**NPI  
PROFILES**

**TS** 910  
**DIN** 1025

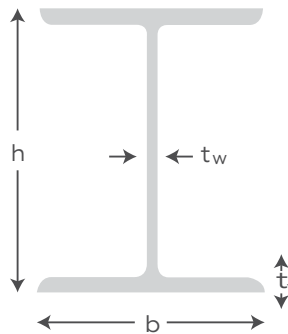

Dimensions (mm)			
h	b	tw	tf
80 - 600	42 - 215	3,9 - 21,6	5,9 - 32,4

**UPE  
PROFILES**

**TS** 912  
**DIN** 1026

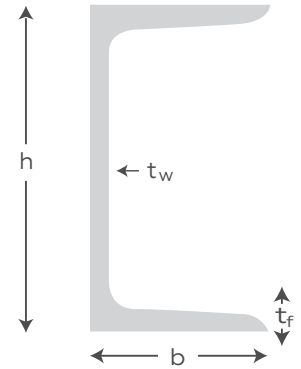

Dimensions (mm)			
h	b	tw	tf
80 - 400	50 - 115	4,0 - 13,5	7,0 - 18,0

HEA  
PROFILES

TS 910/1  
DIN 1025

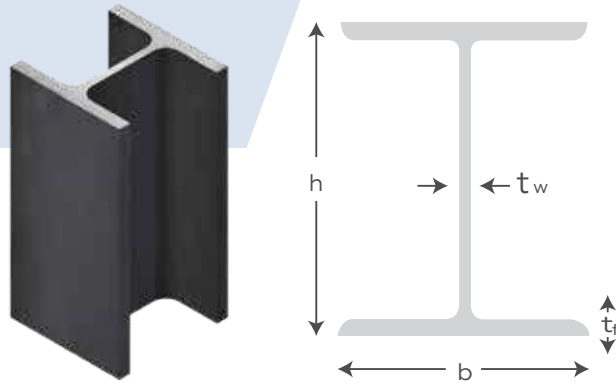

Dimensions (mm)			
h	b	tw	tf
100 - 1000	100 - 300	5 - 16,5	8 - 31

HEB  
PROFILES

TS 910/1  
DIN 1025

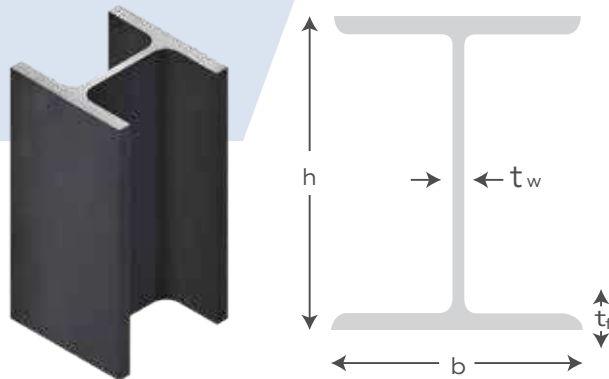

Dimensions (mm)			
h	b	tw	tf
100 - 1000	100 - 300	6,0 - 19,0	10 - 36



**TS 908**  
**DIN 1028**

**EQUAL ANGLES**

Dimensions (mm)

b	s
20x20 - 250x250	3 - 28

**TS 3024**  
**DIN 1017**

**FLAT BARS**

Dimensions (mm)

b	a
10 - 250	5,00 - 50,00

T STEELS - FLAT SQUARE / STEEL BARS

**TS 911**  
**DIN 1024**

**T STEELS**

Dimensions (mm)

t	h	b	s
20 - 140	20 - 140	20 - 140	3 - 15

**TS 911**  
**DIN 1024**

**FLAT SQUARE / STEEL BARS**

Dimensions (mm)

mmxmm	kg/mm	mmxmm	kg/mm
8x8 - 65x65	0,50 - 33,20	70x70 - 250x250	38,50 - 490,6

**TS** EN 10219-1 / EN 10305-5

**DIN** 2395-1 / 2

## SQUARE PROFILES

dimensions (mm)	Thickness (mm)
10x10 - 500x500	0,60 - 16,00



## RECTANGULAR PROFILES

**TS** EN 10219-1 / EN 10305-5

**DIN** 2395-1 / 2

## RECTANGULAR PROFILES

Outer Diameter	Thickness (mm)
10x20 - 300x500	0,60 - 16,00

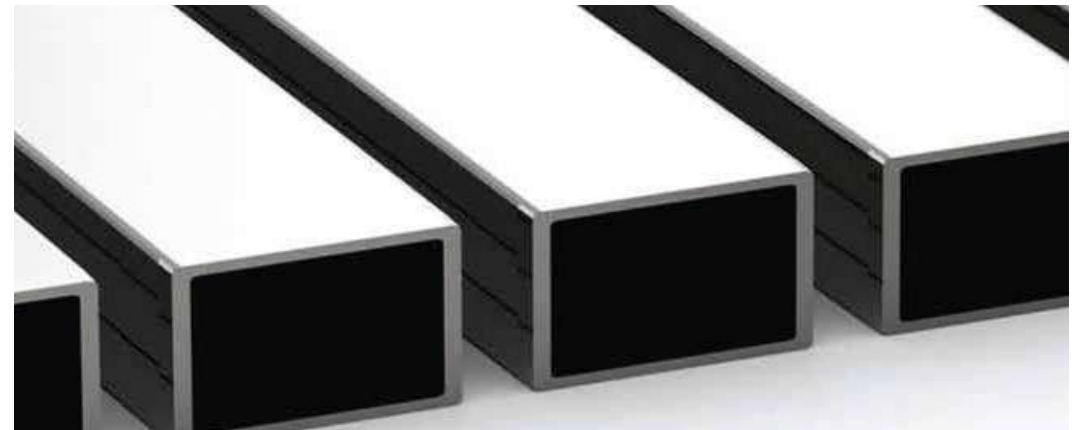

**TS** EN 10255  
**DIN** 2240 - 2241 BS1387

## WATER and GAS PIPES

Black Threaded Sleeve		Galvanized Threaded Sleeve	Black Flat Tip	Galvanized Flat End
Nominal Diameter		Outer Diameter		Thickness
inç	mm	mm		mm
1/2 - 13	10 - 300	21,3 - 339,7		2,35 - 6,30

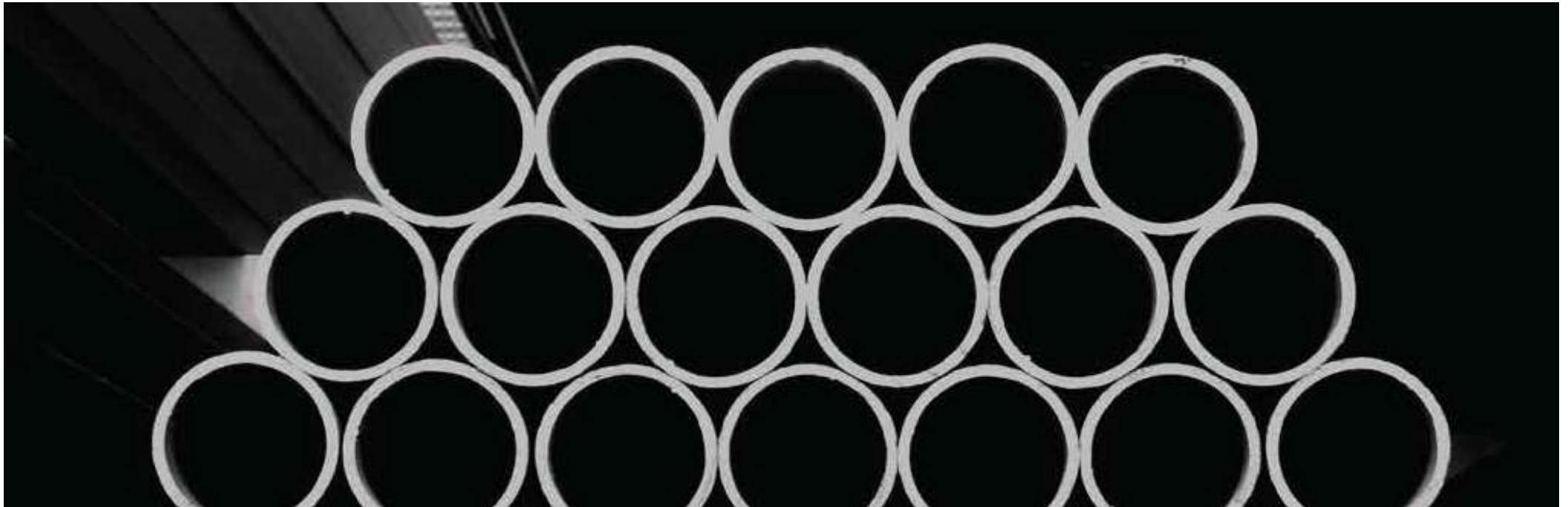

**TS** EN 10219-1 / EN 10305-5  
**DIN** 2394-2458

**INDUSTRIAL / GALVANIZED / BOILER PIPES**

Outer Diameter	Thickness (mm)
323,9	0,60 - 12,50



## DKP SHEETS

Flat steel products in coil or sheet form, produced by cold rolling hot rolled flat steels and ranging in thickness from 0.20-2.00 mm.

Erdemir Quality - Euro EU

6112 - DC01 / 6113 - DC03 / 6114 - DC04 / 7114 - DC04



## PATTERNED SHEETS

Patterned / tear drop sheet is a type of sheet produced from hot rolled steel. It has a non-slip and robust structure.

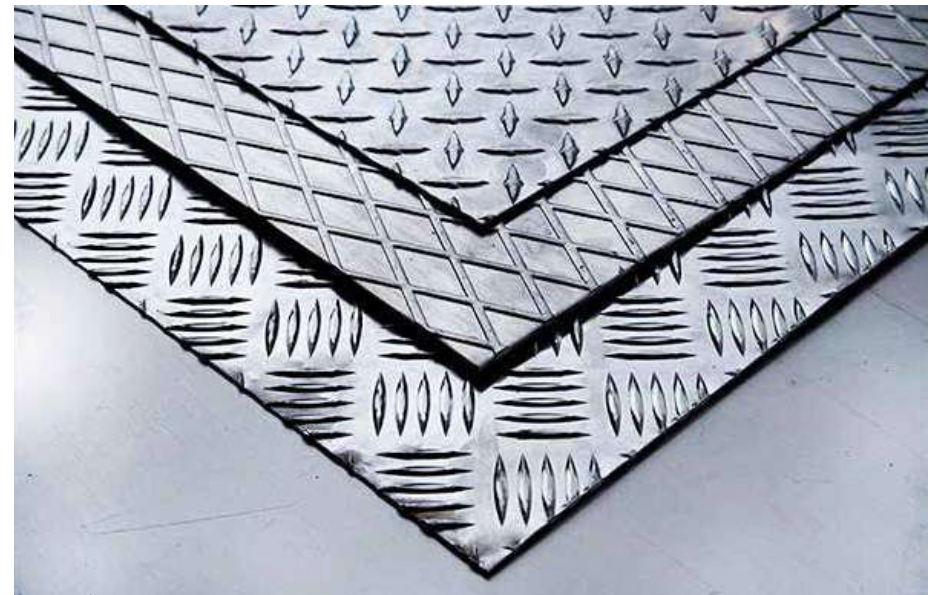

Thickness (mm)

Dimensions (mm)

1000x200 - 2000x1200

2,00 - 3,00 / 9,00 - 10,00



## HOT ROLLED SHEET

Flat steel products obtained by rolling the rectangular cross-sectional semi-product (slab) produced by continuous casting method at a certain temperature. Coil or sheet from coil: Roll products with thicknesses ranging from 1.20-25.00 mm or sheet products cut to length/sliced from coil. Plate: Products with thicknesses between 6.00 - 200.00 mm and widths between 1000-3600 mm.

Erdemir Quality		Euro EU	
3237	3244	S235JR	S275JR
3252	4237	S355JR	S235JR
4244	4252	S275JR	S355J2
4932	4936	S315MC	S355MC
4942	4946	S420MC	S460MC
4950	6052	S500MC	S355J2C
6244	6252	S275J2	S355J2



## HRP ACID SHEET

The surface of hot rolled coil sheets remains rough during the rolling process. In order for the sheet to enter the HRP form, the hot rolled sheets are pickled in pickling lines and thus the surface is cleaned. It is then offered to users as rolls and sheets.

Erdemir Quality		Euro EU	
3237	3244	S235JR	S275JR
3252	4237	S355JR	S235JR
4244	4252	S275JR	S355J2
4932	4936	S315MC	S355MC
4942	4946	S420MC	S460MC
4950	6052	S500MC	S355J2C
6244	6252	S275J2	S355J2



## GALVANIZED SHEET

Galvanized flat steels are produced by coating both surfaces of cold rolled metal with a layer of zinc as a result of hot dipping. After the zinc coating is formed on the steel surface, galvanized flat steels are produced by converting the coating on the intermediate surface into a zinc iron alloy layer as a result of induction heating.

Erdemir Quality		Euro EU	
1311	1312	DX51D+Z	DX52D+Z
1313	1314	DX53D+Z	DX54D+Z
1315	1322	DX56D+Z	S220GD+Z
1325	1328	S250GD+Z	S280GD+Z
1332	1335	S320GD+Z	S350GD+Z



## PAINTED SHEET

Prepainted Sheet; cold rolled coil sheets in certain proportions. It is obtained by processing with polyester-containing paints after galvanized coating. In addition to polyester-containing paint, Plastisoli is used with Polyurelan and PVDF paint qualities. Painted sheets are preferred because they are both resistant to corrosion and aesthetically more decorative.

Erdemir Quality
DX51 - DX52



## 27-200 TRAPEZE (SHEET OPENING WIDTH: 1000 and 1200 mm)

### TRAPEZE 1

Galvanized Trapezoidal Sheet 27-200. It is the form of galvanized coils as trapezoidal sheet. It is produced in 27/200 form. Formed trapezoidal sheet widths; 1000 mm width to 860 mm (Useful Area: 800 mm), It is produced in 1200 mm width and 1050 mm (Useful Area: 1000 mm).



Spring Load Capacity (kg/m <sup>2</sup> )	
Purlin Spacing (m)	Thickness (mm)
1,00 - 3,00	0,40 - 1,05

1 Plate Trapeze Weight	
Purlin Spacing (m)	Thickness (mm)
2 mt - 6 mt	0,40 - 1,00

## 38-151 TRAPEZE (HAIR OPENING WIDTH: 1200 mm)

### TRAPEZE 2

Galvanized Trapezoidal Sheet 38-151. It is the form of galvanized coils as trapezoidal sheet. It is produced in 38/151 form. Formed trapezoidal sheet widths; 1200 mm width to 975 mm (Useful Area: 906 mm).

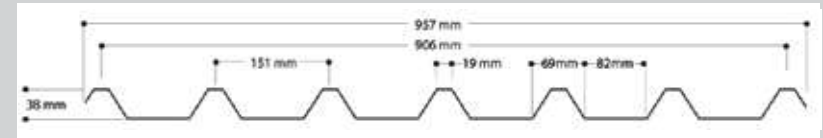

Spring Load Capacity (kg/m <sup>2</sup> )	
Purlin Spacing (m)	Thickness (mm)
1,20 - 3,00	0,50 - 1,20

1 Plate Trapeze Weight	
Purlin Spacing (m)	Thickness (mm)
2 mt - 6 mt	0,50 - 1,20

## REBARS

Hot rolled plain and ribbed rebar in the diameter range of 8 mm - 40 mm



Ribbed and Plain Rebar Bill of Quantities		
Length Width	mt/kg	12mt / kg
m		
8mm x 40mm	0,395 - 9865	4,750 - 118,380



## RECTANGULAR

## Q SQUARE

## R TYPE STEEL MESH

## Q TYPE STEEL MESH

R Type Steel Mesh Tables						
Mesh Types	Range		Diameter		Interocular Distance	
	Length	Width	Length	Width	Length	Width
	mm					
R 106	500	215	4,5	4,5	15	25
R 633			11,0	6,5		

Q Type Steel Mesh Tables						
Mesh Types	Range		Diameter		Interocular Distance	
	Length	Width	Length	Width	Length	Width
	mm					
Q 106 / 106	500	215	4,5	4,5	15	15
Q 754 / 754			12,0	12,0		

## ROUND - SQUARE - HEXAGONAL STEELS



Round Steels	Square Steels	Hexagonal Steels
2 - 80 mm Cold	0,00785 - 5,723	0,00680 - 4,957
20 - 160 mm Bark Peeling	8 x 8 - 100x100 mm Hot	16 x 102 Hot
8 - 260 mm Hot	6 x 6 - 80 x 80 mm Cold	7 x 60 mm Cold
20 - 1200 mm Forging		

**Angle Strip Saw Machine  
(Up to Diameter Q400)**



**Q350 Pipe-Profile  
Laser Machine  
Up to Diameter**



**Bending Machine  
(Up to 12mm)**



**Hydraulic  
Guillotine  
Shear  
(Up to 15mm)**



**2500x6500  
Table 22 kW  
Laser Machine  
(Up to 60mm)**



**"We aim to provide services to meet all the iron and steel needs of users with high-quality production, economical solutions, fast and flexible service in the iron and industries"**



**You can easily access address,  
location and directions  
by scanning QR code**





[www.dehametal.com](http://www.dehametal.com)

Deri Organize Sanayi Mah.  
Lazer Sokak No:13/A Tuzla - İstanbul - Türkiye

T:+90 216 394 27 72    info@dehametal.com  
F: +90 216 394 27 75    satis@dehametal.com



Contact Us